

## GWR HALL CLASS INSIDE MOTION

### ETCHED COMPONENTS

- M30 Eccentric sheath (4)
- M31 Fore gear expansion link (2)
- M32 Back gear expansion link (2)
- M33 Expansion link hanger (2)
- M34 Reversing arm lamination (4)
- M35 Link hanger (2)
- M36 Rock shaft lever (2)
- M37 Extension rod (2)

### OTHER COMPONENTS

- 1/16" Brass tube for rock shaft
- Short rivets (10)
- 0.8mm Steel wire for rock shaft
- 0.7mm Brass wire for pinning eccentrics
- 0.8mm Brass wire for stuffing box studs
- 1.2mm Brass wire for link hanger pivot
- 1.6mm Brass wire for reversing shaft
- Brass eccentrics left (2)
- Brass eccentrics right (2)

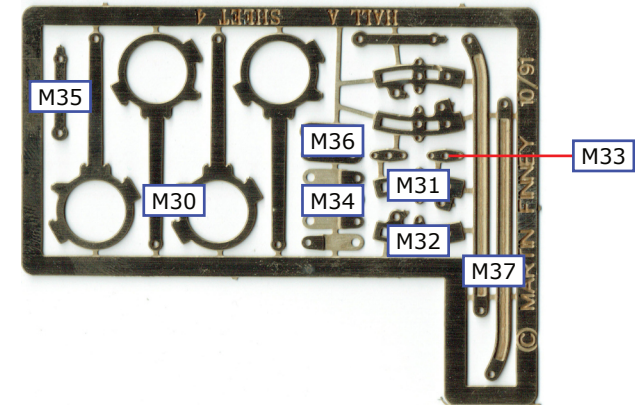

The valve gear kit is designed to produce a working model of the Stephenson's link valve gear. For practicality two deviations from the prototype have been made. First the link block hangers have been omitted and instead the motion is suspended from the reversing shaft; there are no separate link blocks and the motion is permanently in full forward gear. Second the rock shafts which transfer the motion over the frames from the inside to the outside are omitted. The drive for the valve rods is taken directly through a slot in the frames.

Most of the drawings to describe this build are on the reverse side of this piece of paper. Study the diagrams carefully. The right side eccentrics lead the left by 90° to match the crankpins. The left side of the motion mirrors the right lagged by 90°. Chemically blacking moving surfaces at soldered joints can help ensure that the solder only goes where it is needed.

### CRANK AXLES AND ECCENTRICS.

This uses solder and pin construction. Use 60/40 cored solder with plenty of La-Co flux paste and a micro flame to generate enough heat. Use a sacrificial cheap brush and brush more flux round the axle whilst hot. More solder is good! Either solder the complete assembly in one go or assemble and then solder the left eccentrics to the left crank followed later by the right side. Solder each side in place on the axle separately.

**Eccentrics.** Ream out the holes in the eccentrics so that they are a tight fit on the axle. Then carefully open out the small holes in the eccentrics, so that the 0.7mm wire fits in the holes. Check the fit of the eccentric sheaths on the eccentrics. Drill a 3/16" hole in a small block of wood leaving the drill in the hole to act as a mandrel to align the eccentrics. Assemble the eccentric sheaths, eccentrics and 0.7mm wire pin in pairs over the mandrel and solder the wire pin to both eccentrics. Cut the wire flush with the face of the eccentrics.

**Cranks.** Completely drill a hole on each side through the cranks down the narrowest part from top to bottom, either 0.7mm or 0.8mm depending on width of crank.

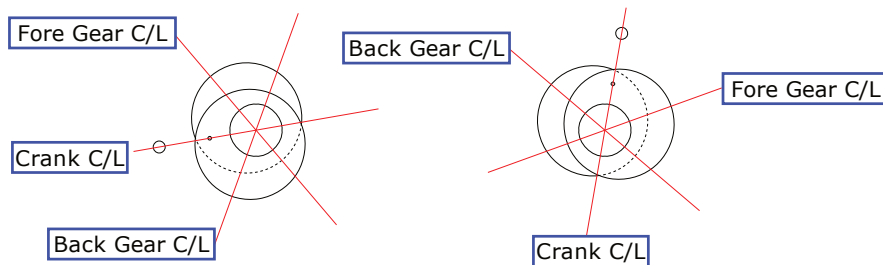

Right Side From Centreline

Left Side From Centreline

**Assembly.** Fit the eccentrics to the crank axle using the drawing to ensure correct orientation. The eccentric should be fixed at 6mm centres for finescale and 8mm centres for S7. It is probably easiest to mark the inner alignment of the eccentrics on the axle. Space the eccentrics on the axle so that pairs of eccentrics are at the correct centres and they are in the correct position with respect to the cranks.

Allow everything to cool and then re-drill through the holes in the cranks, this time going through the axle. Add a pin through each of the holes, then add more flux and solder pins in place. Check all joints are properly soldered, clean up and cut through the axle.

**Reversing Shaft.** Solder the reversing shaft laminations to the 1.6 mm wire reversing shaft so that the reversing arms are at 4 mm centres for Finescale and 6 mm for S7. Trim the left hand end of the shaft so that it fits in the housing on the left frame while the reversing arms are centred on the frame centreline and that sufficient wire projects through the right frame to later fit the reversing shaft lower arm (U37). Open the hanger pivot holes in the reversing arms to 1.2 mm so that the wire is a tight fit.

**Testing.** Fit the axle and bearings into the centre horn guide and fit the rock shaft tubes through the slots in the frames. Temporarily suspend the extension rods and rock shafts with a piece of wire through the frame brackets; a suitable piece of wire insulation can space the rock shafts apart. Fit a piece of 1.2 mm wire to suspend the link hangers. The valve gear should move without flopping about.

**Finishing.** The valve gear is permanently fixed by riveting the rock levers to the frame brackets and soldering the link hanger suspension wire in place. Solder the reversing shaft to the frames.

Trim the brass tubes so that a 4.5 mm pin in the valve rod fits in the tube and the valve rod moves freely into the valve chest.

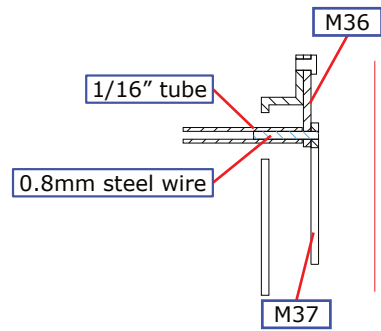

Section AA

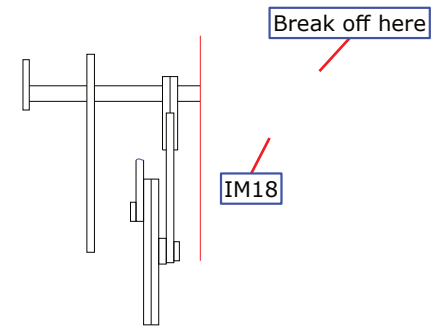
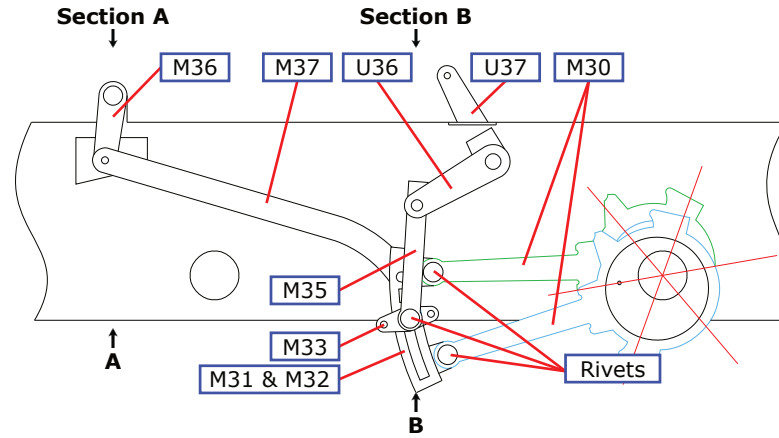

Section BB

Section Showing Elevation of Right Valve Gear

